

LOW-PROFILE AIR SHOWERS

CAP701LP-ST

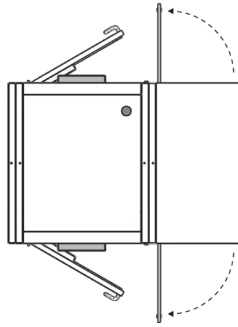

Quality construction

- Durable heavy-gauge painted steel
- High velocity and air volume rate for fast, efficient cleaning
- Inspection panels for high-pressure supply ducts

Easy electronics

- Microprocessor controller, touchscreen controls
- Magnetic interlocks
- LED lighting

Advanced filters and sealants

- Urethane sealant
- Standard-size HEPA filters and prefilters
- Zero-leak, negative-pressure reliability seal on HEPA filter gasket

Optimal configuration

- Easy service access
- Customization options

For a full description see the
CAP air showers brochure.



CAP701LP-ST low-profile straight-through air showers are 95 inches high, feature side-mounted HEPA filters and can be ordered pre-assembled.

CAP701LP air showers can be custom-designed and ordered in a variety of configurations, including 90-degree left or right turn; 3-door (multiple entrance and exit combinations); tunnel (straight-through with multiple sections); double doors; ADA compliant; decontamination; and wall mount. See separate data sheets.

Clean Air Products low-profile air showers feature rugged construction and adjustable, high velocity air jets. The 16-gauge painted steel shell (*stainless steel* optional) with heavy-duty glass door and door closer withstand the rigors of shipping, installation and daily use. Steel construction reduces the chances of biological growth and contamination.

A powerful 3-phase 5 HP blower motor provides approximately 1900 CFM at 7800 LFM. This high air-flow volume (power) combined with the high nozzle velocity (force) quickly and efficiently clean personnel inside the air shower.

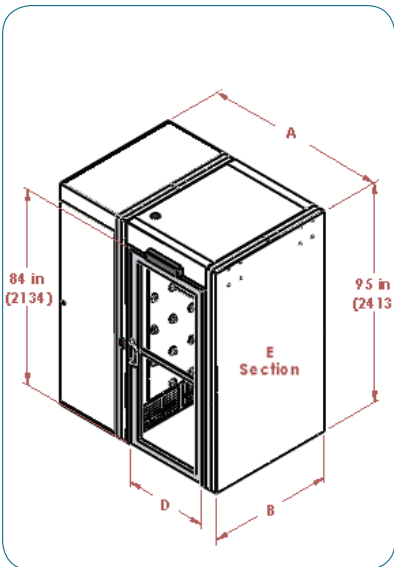
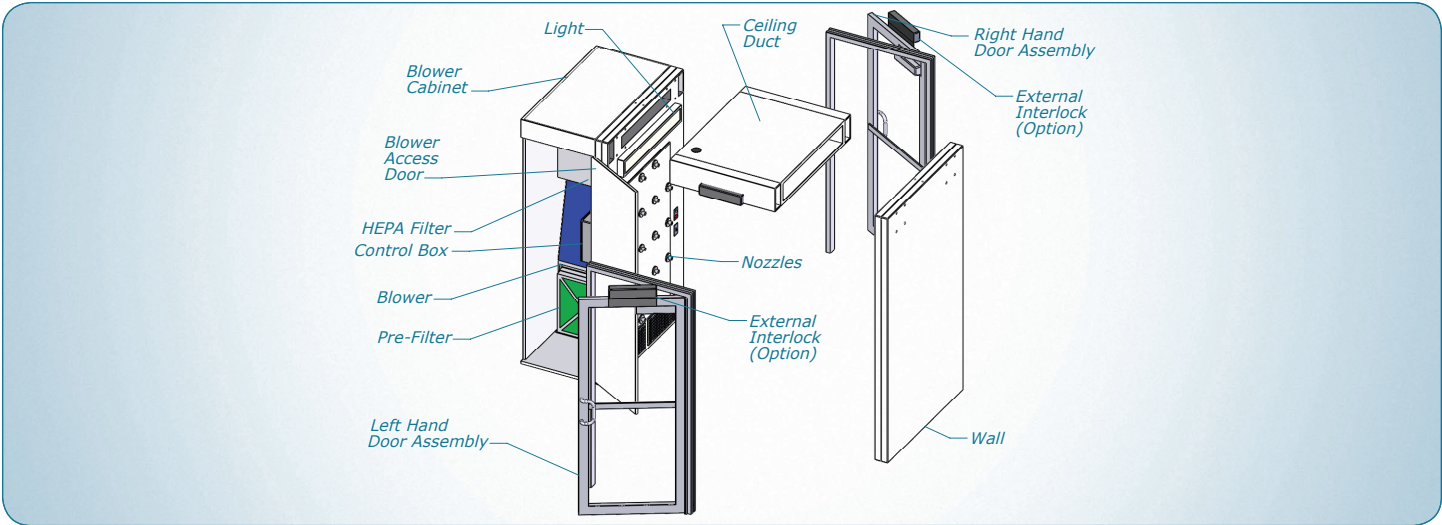

PRODUCT DIMENSIONS: inches (mm) (Common sizes – additional sizing available)					
Model Number	A Outside width	B Outside depth	D Door width	Qty of E 54 in. sections	Qty of E 72 in. sections
CAP701LP-ST-4954	77.75 (1975)	54 (1372)	36 (914)	1	0
CAP701LP-ST-4972	77.75 (1975)	72 (1829)	36 (914)	0	1
CAP701LP-ST-5554	83.75 (2127)	54 (1372)	42 (1067)	1	0
CAP701LP-ST-5572	83.75 (2127)	72 (1829)	42 (1067)	0	1
CAP701LP-ST-6154	89.75 (2280)	54 (1372)	48 (1219)	1	0
CAP701LP-ST-6172	89.75 (2280)	72 (1829)	48 (1219)	0	1

LEARN MORE

Clean Air Products designs the CAP701 Series air showers for optimal performance, customization, configuration and maintenance. For more information on CAP701 Series air showers including CAD drawings, RFQs, purchase specifications, exploded views and options, visit:

www.cleanairproducts.com/product-category/air-showers



www.cleanairproducts.com

8605 Wyoming Ave. N. • Minneapolis, Minnesota 55445
763.425.9122 • 800.423.9728 • fax: 763.425.2004
e-mail: sales@cleanairproducts.com