

3-DOOR AIR SHOWERS

CAP701KD-3DRH and CAP701KD-3DLH

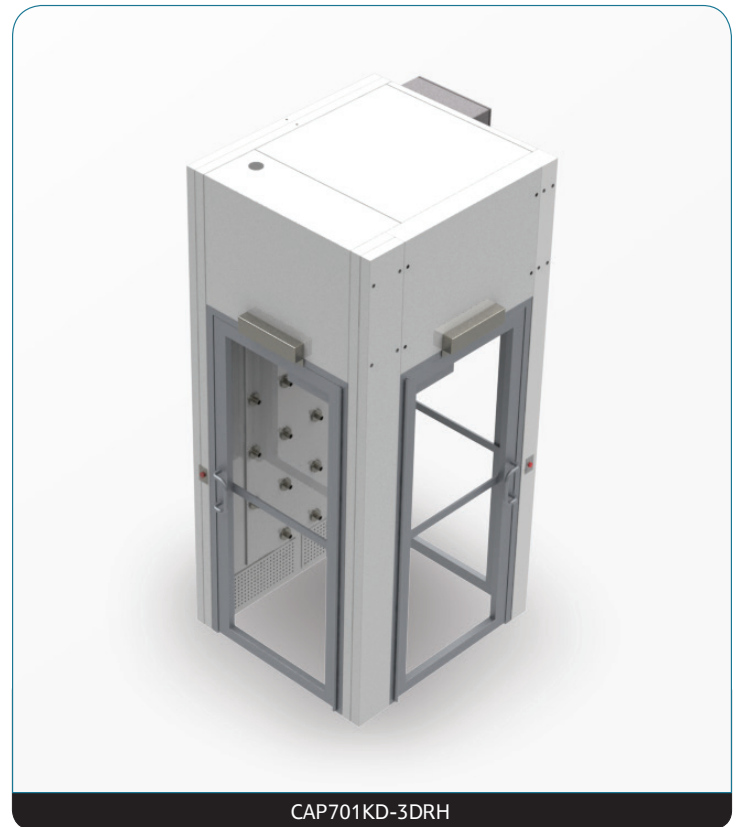
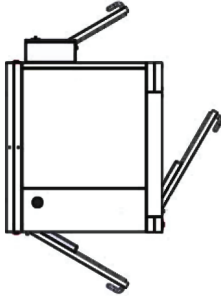

CAP701KD-3DRH

Quality construction

- Durable heavy-gauge painted steel
- High velocity and air volume rate for fast, efficient cleaning
- Inspection panels for high-pressure supply ducts

Easy electronics

- Microprocessor controller, touchscreen controls
- Magnetic interlocks
- LED lighting

Advanced filters and sealants

- Urethane sealant
- Standard-size HEPA filters and prefilters
- Zero-leak, negative-pressure reliability seal on HEPA filter gasket

Optimal configuration

- Easy service access
- Customization options

For a full description see the
CAP air showers brochure.

CAP701KD-3D air showers are equipped with three out-facing doors installed with right- or left-hand turns. The typical configuration is one entrance door and two doors exiting to two different cleanrooms. Multiple entrance and exit combinations are available. Consult the factory with your specific requirement.

CAP701KD-3D air showers can be custom-designed and ordered in a variety of configurations, including low-profile and ADA-compliant.

Clean Air Products air showers feature rugged construction and adjustable, high velocity air jets. The 16-gauge painted steel shell (*stainless steel* optional) with heavy-duty glass door and door closer withstand the rigors of shipping, installation and daily use. Steel construction reduces the chances of biological growth and contamination.

A powerful 3-phase 5 HP blower motor provides approximately 1900 CFM at 7800 LFM. This high air-flow volume (power) combined with the high nozzle velocity (force) quickly and efficiently clean personnel inside the air shower.

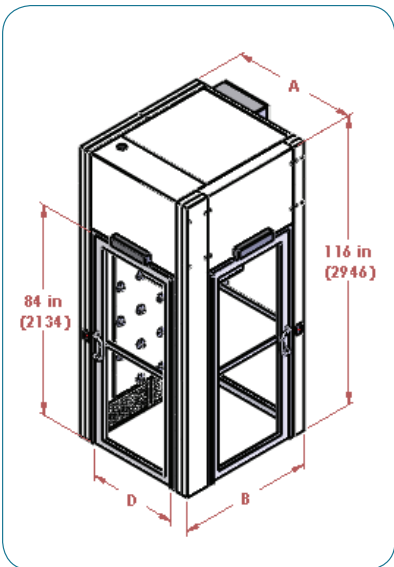
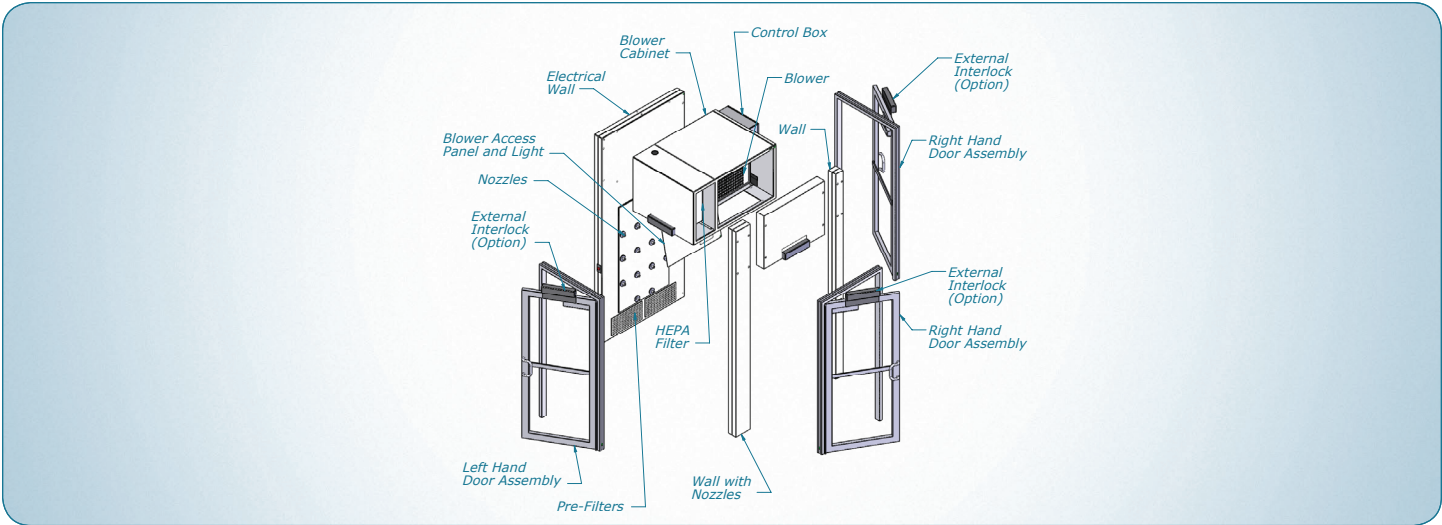

PRODUCT DIMENSIONS: inches (mm) (Common sizes – additional sizing available)					
Model Number	A Outside width	B Outside depth	D Door width	Qty of E 54 in. sections	Qty of E 72 in. sections
CAP701KD-3DRH-4954	49.75 (1264)	54 (1372)	36 (914)	1	0
CAP701KD-3DRH-4972	49.75 (1264)	72 (1829)	36 (914)	0	1
CAP701KD-3DLH-4954	49.75 (1264)	54 (1372)	36 (914)	1	0
CAP701KD-3DLH-4972	49.75 (1264)	72 (1829)	36 (914)	0	1

LEARN MORE

Clean Air Products designs the CAP701 Series air showers for optimal performance, customization, configuration and maintenance. For more information on CAP701 Series air showers including CAD drawings, RFQs, purchase specifications, exploded views and options, visit:

www.cleanairproducts.com/product-category/air-showers



www.cleanairproducts.com

8605 Wyoming Ave. N. • Minneapolis, Minnesota 55445
 763.425.9122 • 800.423.9728 • fax: 763.425.2004
 e-mail: sales@cleanairproducts.com