



Series 62

Cleanroom Tables, Stainless Steel

S
N
O
I
T
L
E
S

All-stainless-steel construction makes these tables a superior, solid-top, cleanroom table solution. Series 62 stainless steel tables are designed for use in cleanrooms of Class 100,000 to Class 10. They are designed for quality, cleanliness and durability, and provide superior cleanroom performance. The tables are constructed of heavy-gage stainless steel, including the legs, gussets and underside bracing. The tables feature under-table cross bracing to provide a strong, flat work surface. All outside edges are formed to provide smooth, rounded corners. The work surface is supported by square, tubular support legs and has a heavy-duty, leg-leveling glide.

Features

- ❖ Stainless steel support frame
- ❖ Compatible with cleanrooms Class 100,000 to Class 10
- ❖ Common sizes in stock for immediate shipping

Series 62 Cleanroom Tables

The stainless steel used in these tables will not crack, chip or corrode and is free from particulate generation. It is ideal in applications where heavier loads or impact may cause standard formica tables to crack or break. The table top has a heavy-duty frame that is supported by tubular stainless steel legs with adjustable leg-leveling glides. The unit is shipped knocked down and easily re-assembles.

The Series 62RT recessed table top has a 3/4-in. liquid-tight recessed center area. This is ideal to contain water or other types of materials. Options include "X" bottom with drain or welded-in sink and water gooseneck.

Options

- Adjustable legs 30 in. to 36 in., in 2 in. increments
- Casters with leg braces
- Cut outs
- Drawers
- Foot rest
- Goosenecks
- Keyboard pull-out trays
- Outlet strips
- Rounded front edge of table top
- Plastic-bottom, leg-leveling glides
- Shelves, upper and lower
- Sink – welded or set-in
- Heavy-duty leg bracing (used with casters, heavy loading or with dynamic loads)

Other options available upon request.

Guarantee

A written 1 year warranty is furnished with each cleanroom table.

CAP62

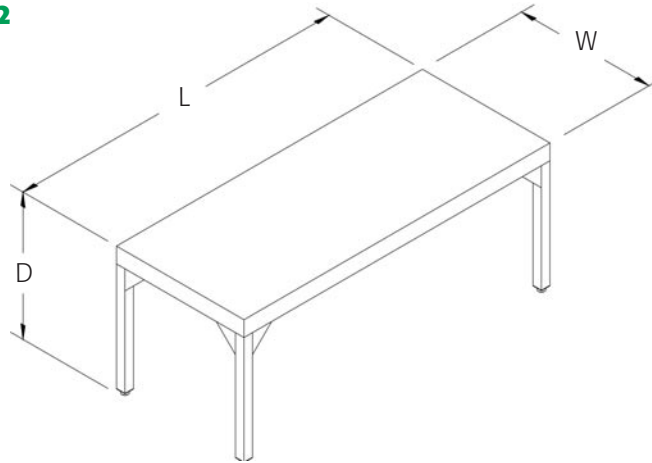

CAP62RT

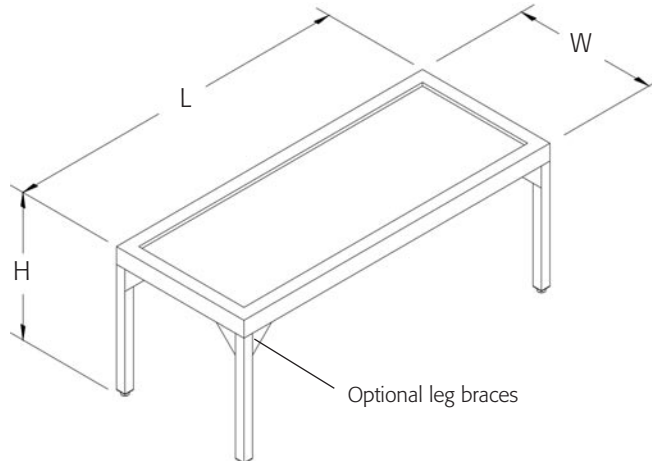

Series 62

Standard Sizes (dimensions in inches)

Length	36	48	72	84	96	108	120
Width	24	30	36	42			
Height	30	34	36				

Other sizes available upon request.

Specifications subject to change. Please contact factory for details.



Solutions Built to Your Specifications.

8605 Wyoming Ave. N. • Minneapolis MN 55445

tel: 763.425.9122 800.423.9728 fax: 763.425.2004

e-mail: sales@cleanairproducts.com www.cleanairproducts.com