

# CAP 18WTI

## Wall Mount Pass Thru

S  
N  
O  
I  
T  
U  
T  
O  
S

The CAP18WTI Wall Mounted Top Interlock Pass Thru airlock cleanroom entry system is Clean Air Product's customized configuration solution. By moving the optional mechanical interlock from the standard right side location to the top of the door frame, customers can specify doors that swing left, or in different directions—a benefit for cleanrooms with obstructions on one or both side walls that would interfere with the door swing of the standard right swing CAP18W PassThru doors.

Like every CAP18W model, the CAP18WTI consists of a heavy duty stainless steel body and doors with smooth, strong surfaces that are durable and easy to clean. Doors attach with stainless steel continuous flush mount hinges, have generously sized tempered safety glass viewing windows and a stainless steel heavy duty over center compression latch that tightly seals against closed cell PVC foam floor gaskets to minimize air leaks.

The CAP18WTI is the custom solution for wall mounting a PassThru in a challenging location, and upgrading the looks of any cleanroom.



For more information or to download or fax this product from the web, go to:  
[www.cleanairproducts.com/18W](http://www.cleanairproducts.com/18W)

## Standard features

- Formed and stitch-welded Type 304 #4 Stainless steel construction
- Design allows door swings to be chosen by customer
- Stainless steel continuous flush-mount hinges
- Clear Tempered Safety Glass viewing windows
- Type 316 Stainless Steel Lever compression door latches
- Closed-cell PVC door gaskets

## Options

- Door swing: Both doors Right Hand Swing or Left Hand Swing, one swings Right, one swings Left
- Electropolished Type 304 #4 Stainless steel
- Type 316L #2b finish Stainless steel
- Electropolished Type 316L #2b finish Stainless steel
- Powder Coated Painted cold rolled Steel (Clean Air Products standard white or customer -specified color)
- Stainless steel mounting frame
- Flush style mounting frame
- Sloped Top mounting frame
- Doors with acrylic, acrylic amber, polycarbonate, PVC, or conductive PVC in the viewing window
- Solid stainless steel doors (no window)
- Mechanical Interlock
- Internal Mount Magnetic Interlock
- Stainless steel Support Gussets
- Stainless steel Adjustable Shelf
- Non-Adjustable or Adjustable Shelf
- Solid or Perforated Shelf
- Combination and Key-Locking 90-Degree Turn Door Cam Latches
- Key-Locking Chrome Plated Zinc Lever Compression Door Latches
- Dual Type 316 Stainless Steel Lever Compression Door Latches with Bar Handle
- Stainless steel Catch Tray
- UV Light with or without timed shut off

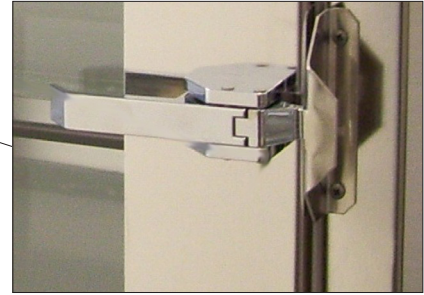

Specifications subject to change. Please contact factory for details.



Solutions Built to Your Specifications.

8605 Wyoming Ave. N. • Minneapolis MN 55445

tel: 763.425.9122 800.423.9728 fax: 763.425.2004

e-mail: sales@cleanairproducts.com www.cleanairproducts.com

# CAP 18WTI Top Interlock Pass Thru Air Lock Cleanroom Entry System

CLEAN ROOM ENTRY SYSTEMS

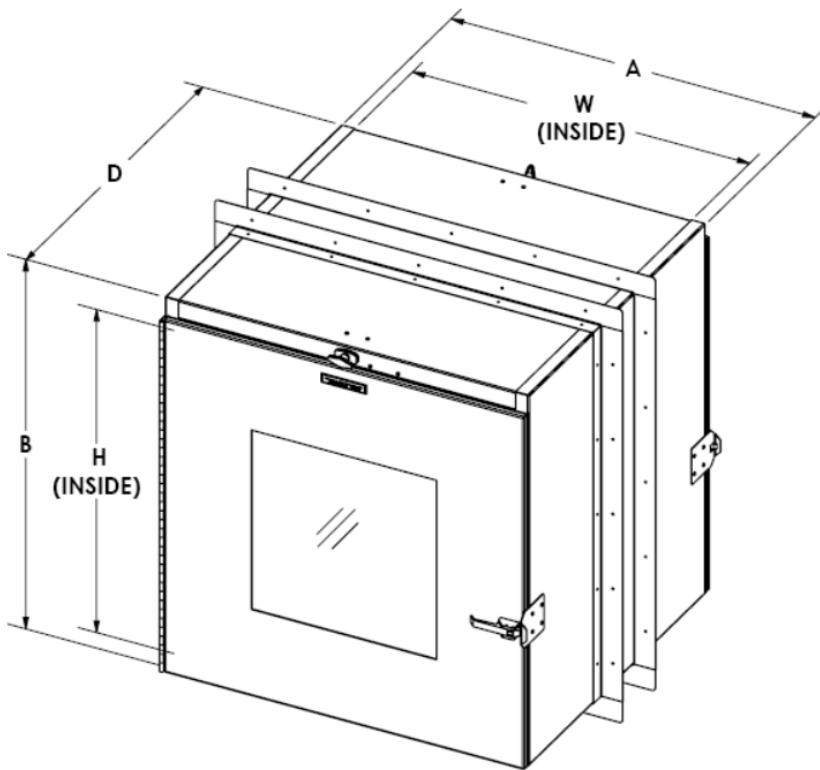

Wall Mount — Dimensions (inches)

CAP18WTI Pass Thrus

MODEL #	Inside Dimensions			Outside Dimensions	
	W	H	D	A	B
CAP18WTI-SST-12Wx12Hx12D	12	12	12	14	16.25
CAP18WTI-SST-18Wx18Hx18D	18	18	18	20	22.25
CAP18WTI-SST-24Wx24Hx24D	24	24	24	26	28.25
CAP18WTI-SST-30Wx30Hx30D	30	30	30	32	34.25
CAP18WTI-SST-36Wx36Hx36D	36	36	36	38	42.25
CAP18WTI-SST-42Wx24Hx30D	42	42	30	44	46.25
CAP18WTI-SST-42Wx36Hx42D	42	42	42	44	46.25

## Sizes and Weight

The CAP 18WTI unit sizes are based on inside dimensions. Weight depends on size and options package .

## Guarantee

A written 1 year warranty is furnished with each air lock.

Specifications subject to change. Please contact factory for details.



Solutions Built to Your Specifications.

8605 Wyoming Ave. N. • Minneapolis MN 55445

tel: 763.425.9122 800.423.9728 fax: 763.425.2004

e-mail: sales@cleanairproducts.com www.cleanairproducts.com