



CAP 18WFR

Wall Mount Fire Rated Door Pass Thru

S
N
O
I
T
U
T
O
S

The CAP18WFR Wall Mounted Fire Rated Pass Thru airlock cleanroom entry system is designed for those cleanrooms that are required to meet state and local fire codes. As with all CAP Pass Thrus, it is built with an innovative double wall design, stainless steel integrity, and solid construction.

The CAP18WFR door is a 90 minute white painted steel fire rated door in a white painted steel door frame. The door has a 10 inch by 10 inch clear wire safety glass viewing window, steel butt hinge, and chrome plated door handle. The door has an aluminum surface mount door closer.

The CAP18WFR joins CAP high quality engineering and fire rating. The door opposite the fire-rated door has a continuous flush-mounted stainless steel hinge, and is secured with a stainless steel lever compression door latch. An interlock prevents depressurization from both doors from being opened at the same time.

The superior engineering of the CAP18WFR design and stainless steel construction means maximum value, flexibility and ease of use. The CAP18WFR Pass Through is the safe solution for facilities and laboratories to transport flammable substances in and out of their cleanroom environment.



For more information or to download or fax this product from the web, go to:
www.cleanairproducts.com/18W

Standard features

- Formed and stitch welded Type 304 #4 finish Stainless Steel construction
- Aluminum surface mount door closer installed on the fire-rated door
- Stainless steel continuous flush-mount hinge (opposite fire-rated door)
- 90 Minute white painted steel fire rated door with a white painted steel door frame, 10 inch x 10 inch clear wire Safety Glass viewing window, steel but hinge, and chrome plated door handle
- Stainless steel lever compression door latch (opposite fire rated door)



Options

- Electropolished Type 304 #4 finish Stainless Steel
- Type 316L #2b finish Stainless Steel
- Electropolished Type 316L #2b Stainless Steel
- Stainless steel Fire Rated Door
- Fire Rated Mechanical interlock
- Solid or Perforated stainless steel shelf
- Adjustable or Non-adjustable stainless steel shelf
- Key-Locking Chrome Plated Zinc Lever Compression Door Latch
- Stainless Steel Lever Compression Door Latch with Bar Handle
- Stainless steel Support Gussets
- Stainless steel Catch Tray
- UV and Door Position Lights



Specifications subject to change. Please contact factory for details.



Solutions Built to Your Specifications.

8605 Wyoming Ave. N. • Minneapolis MN 55445

tel: 763.425.9122 800.423.9728 fax: 763.425.2004

e-mail: sales@cleanairproducts.com www.cleanairproducts.com

CAP 18WFR Pass Thru Air Lock Cleanroom Entry System

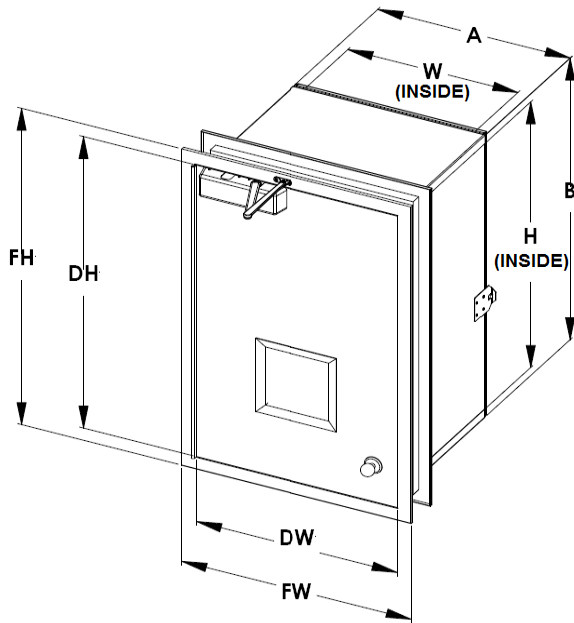

Wall Mount — Dimensions (inches)

CAP18WFR Pass Thrus

MODEL #	Inside Dimension			Outside Dimensions	
	W	H	D	A	B
CAP18WFR-15R-478-SST-19Wx43-1/4Hx24D	19	43.25	24	22.375	46.5
CAP18WFR-15R-478-SST-19Wx43-1/4Hx30D	19	43.25	30	22.375	46.5
CAP18WFR-15R-478-SST-19Wx43-1/4Hx36D	19	43.25	36	22.375	46.5
CAP18WFR-15R-478-SST-25Wx43-1/4Hx24D	25	43.25	24	28.325	46.5
CAP18WFR-15R-478-SST-25Wx43-1/4Hx30D	25	43.25	30	28.375	46.5
CAP18WFR-15R-478-SST-25Wx43-1/4Hx36D	25	43.25	36	28.375	46.5
CAP18WFR-15R-478-SST-31Wx43-1/4Hx24D	31	43.25	24	34.375	46.5
CAP18WFR-15R-478-SST-31Wx43-1/4Hx24D	31	43.25	24	34.375	46.5
CAP18WFR-15R-478-SST-31Wx43-1/4Hx30D	31	43.25	30	34.375	46.5
CAP18WFR-15R-478-SST-37Wx43-1/4Hx24D	37	43.25	24	40.375	46.5
CAP18WFR-15R-478-SST-37Wx43-1/4Hx30D	37	43.25	30	40.375	46.5
CAP18WFR-15R-478-SST-37Wx43-1/4Hx36D	37	43.25	36	40.375	46.5
CAP18WFR-15R-478-SST-41Wx43-1/4Hx24D	41	43.25	24	46.375	46.5
CAP18WFR-15R-478-SST-41Wx43-1/4Hx30D	41	43.25	30	46.375	46.5
CAP18WFR-15R-478-SST-41Wx43-1/4Hx36D	41	43.25	36	46.375	46.5

Sizes and Weight

The CAP 18WFR is available in many standard sizes. Unit sizes are based on inside dimensions. Weight depends on size and options package. Contact us if you have any questions.

Guarantee

A written 1 year warranty is furnished with each air lock.

Specifications subject to change. Please contact factory for details.



Solutions Built to Your Specifications.

8605 Wyoming Ave. N. • Minneapolis MN 55445
 tel: 763.425.9122 800.423.9728 fax: 763.425.2004
 e-mail: sales@cleanairproducts.com www.cleanairproducts.com