



CAP 18FMD

Floor Mounted Man Doors Pass Thru

The CAP18FMD Floor Mounted Man Doors Personnel Pass Thru airlock cleanroom entry system enables passage of personnel in and out of a cleanroom. Personnel transit through Anodized aluminum safety glass doors that easily open and securely close with hydraulic door closers.

During use, doors can be secured with optional magnetic interlocks that avoid air depressurization of the cleanroom by preventing both doors from being opened at the same time.

For added convenience in handling and installation, the CAP18FMD is shipped in “knocked-down” components that will fit through standard doorways and are easily assembled in the field.

The combination of high quality, heavy-duty construction and innovative design found in all Clean Air Products Pass Thrus makes the CAP18FMD the high value choice for personnel access, while providing an elegant, modern look that upgrades the appearance of any cleanroom.



For more information or to download or fax this product from the web, go to:
www.cleanairproducts.com/18W

Standard features

- Formed Type 304 #4 finish Stainless Steel components
- Anodized aluminum Safety Glass doors with hydraulic door closers
- Knock-down" design allows the unit to ship as components that are easily assembled in the field

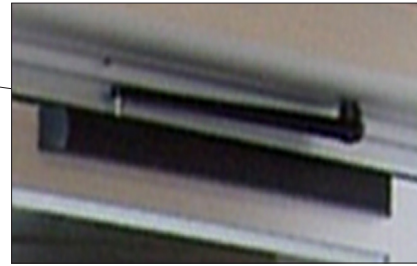

Options

- Electropolished Type 304 #4 finish Stainless Steel
- Type 316L #2 finish Stainless Steel
- Electropolished Type 316L #2 finish Stainless Steel
- Powder coated Painted cold Rolled Steel (Clean Air Products standard white or customer specified color)
- Window options: Clear wired safety glass, Clear laminated safety glass, Clear PVC, ESD PVC, Clear polycarbonate, Clear acrylic, Yellow acrylic, Amber acrylic
- External Mount Magnetic Interlock with 3 EPO Switches and a Keyed Reset
- Internal Mount Magnetic Interlock with 3 EPO Switches and a Keyed Reset
- Stainless steel Mounting Frame
- Stainless steel Flush-Style Mounting Frame
- Stainless steel Sloped Top Mounting Frame
- Painted or Stainless steel door with viewing windows
- Aluminum-framed doors with Type 304 #4 finish Stainless Steel insert in the lower half
- Power Door Openers
- Stainless steel Threshold
- Automatic or Fixed Door Sweeps
- Door Rub Rails
- Duplex Receptacle with Stainless steel cover
- Door Position Indicator Lights
- Ventilation Couplings



Specifications subject to change. Please contact factory for details.



Solutions Built to Your Specifications.

8605 Wyoming Ave. N. • Minneapolis MN 55445
 tel: 763.425.9122 800.423.9728 fax: 763.425.2004
 e-mail: sales@cleanairproducts.com www.cleanairproducts.com

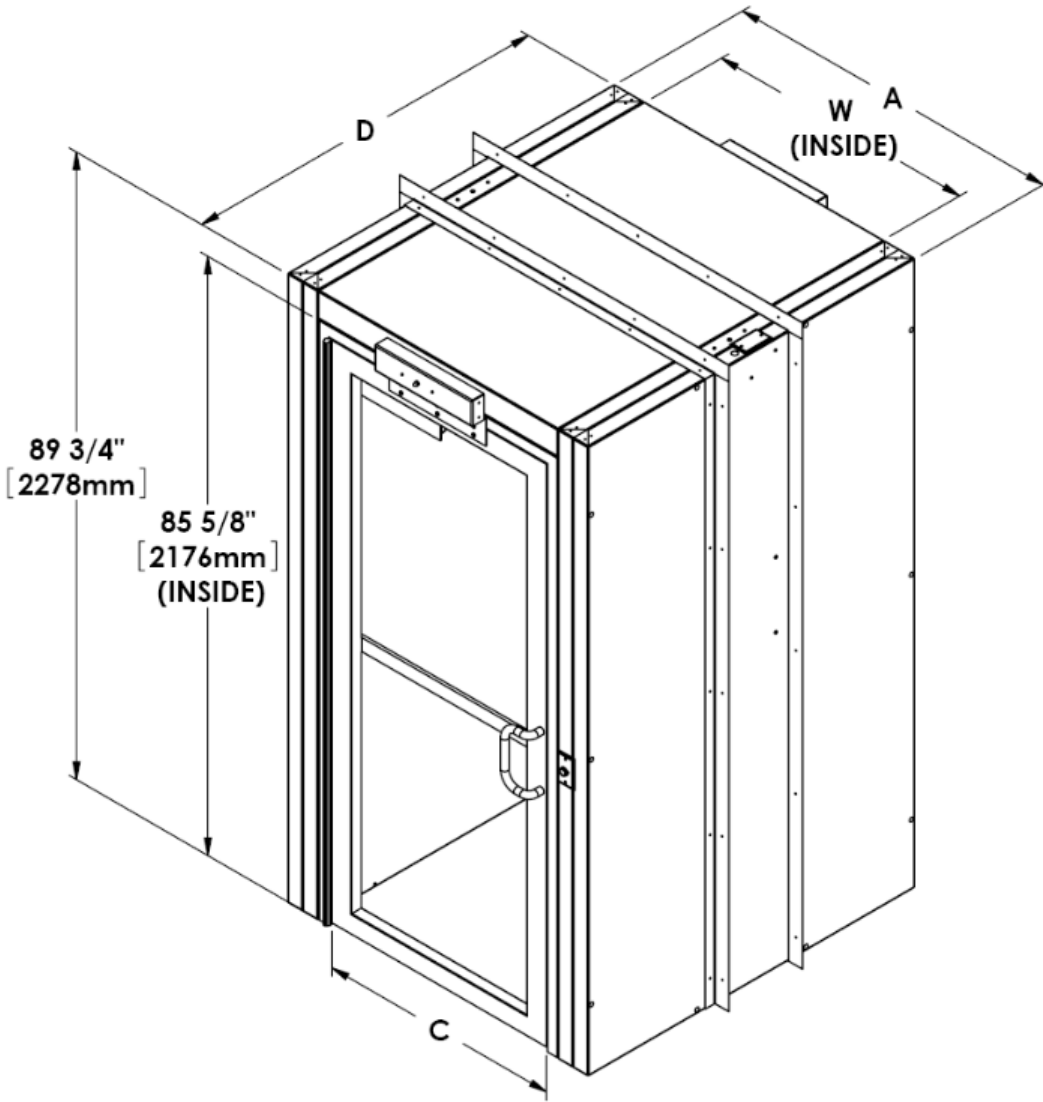

Floor Mount — Dimensions (inches)

CAP18FMD Pass Thrus

Sizes and Weight

Unit sizes are based on inside dimensions.

Weight depends on size and options package. Contact us if you have any questions.

Guarantee

A written 1 year warranty is furnished with each air lock.

MODEL #	Inside			
	W	H	D	Door W
CAP18FMD-SST-39.75Wx86Hx54D	39.75	86	54	36
CAP18FMD-SST-39.75Wx86Hx42D	39.75	86	72	36
CAP18FMD-SST-39.75Wx86Hx84D	39.75	86	84	36
CAP18FMD-SST-45.75Wx86Hx54D	45.75	86	54	42
CAP18FMD-SST-45.75Wx86Hx72D	45.75	86	72	42
CAP18FMD-SST-45.75Wx86Hx84D	45.75	86	84	42
CAP18FMD-SST-51.75Wx86Hx54D	51.75	86	54	48
CAP18FMD-SST-51.75Wx86Hx72D	51.75	86	72	48
CAP18FMD-SST-51.75Wx86Hx84D	51.75	86	84	48

Specifications subject to change. Please contact factory for details.



Solutions Built to Your Specifications.

8605 Wyoming Ave. N. • Minneapolis MN 55445

tel: 763.425.9122 800.423.9728 fax: 763.425.2004

e-mail: sales@cleanairproducts.com www.cleanairproducts.com